



SlideExpress 2

Automated Sample Handling for Microscopy.

Specifications Overall System

Capacity	120 slides 76 × 26 × 1 mm in 3 magazines with 20 clips each with 2 slides each	60 slides 76 × 52 × 1 mm in 3 magazines with 20 clips each with 1 slides each
Changeover time ¹	approx. 15 seconds (per slide)	
Compatibility	Zeiss Axio Imager.Z2, Olympus BX61/63, Nikon Eclipse Ni-E, others on request	
Footprint	97.1 × 51.2 cm (W × L)	
Total height	approx. 102 cm	
Weight	handling system (without magazines) baseplate with adaptation 1 magazine incl. clips and slides ¹	approx. 65 kg approx. 6 kg approx. 26 kg approx. 2.5 kg

Specifications Scanning Stage

Accuracy ²	±1 µm
Repeatability ²	< 1 µm (bidirectional)
Resolution	0.05 µm (smallest step size)
Travel speed	max. 100 mm/s (with 4 mm ball screw pitch)

Order Information

Order information can be found overleaf.

Product Features

- ▶ integrated SCAN^{plus} scanning stage
- ▶ innovative clip concept enables high process reliability and high repeatability
- ▶ integrated measuring systems ensure position monitoring in all axes for safe sample handling
- ▶ vibration damped feet absorb vibrations and prevent slipping of the system
- ▶ quick and easy set up and commissioning
- ▶ low maintenance, high throughput
- ▶ Liquid Dispenser for application of immersion medium available as an optional accessory
- ▶ prepared for barcode scanner integration

For more accessories for microscopy please visit: www.marzhauser.com

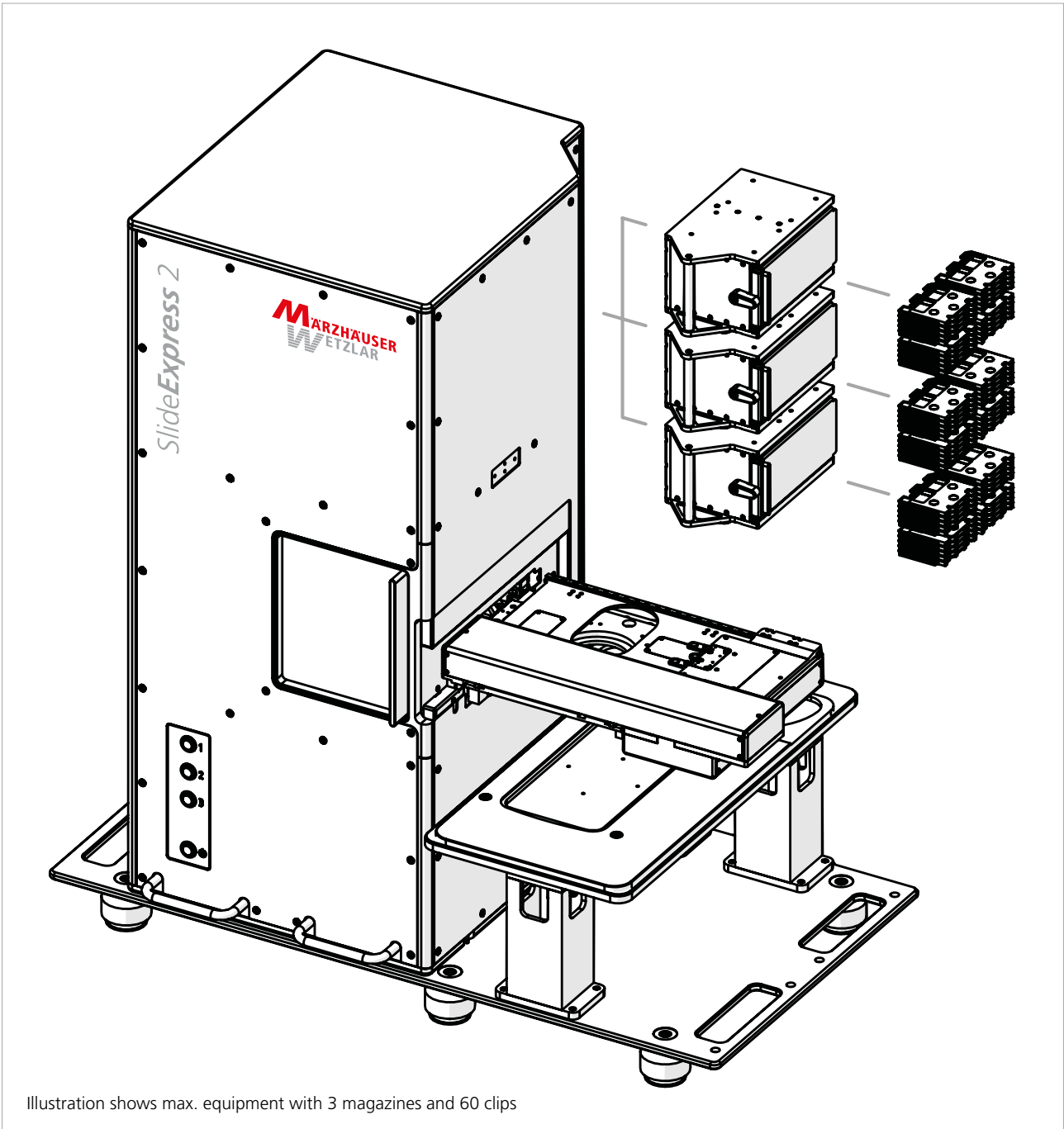

Illustration shows max. equipment with 3 magazines and 60 clips

SlideExpress 2		Order No. ¹		
Handling system, scanning stage, baseplate with adaptation (without magazines)		XX-24-905-0000		
Magazines	Order No.	Clips ²	Order No. 20 Pieces	Order No. 5 Pieces
Magazine incl. 20 clips for 2 slides 76 × 26 mm	00-24-905-3021	Clip for 2 slides 76 × 26 mm	00-24-905-0821	00-24-905-0851
Magazine incl. 20 clips for 1 slide 76 × 52 mm	00-24-905-3022	Clip for 1 slide 76 × 52 mm	00-24-905-0822	00-24-905-0852
Magazine without clips	00-24-904-3810			



¹ order no. depends on microscope type
² single clips available as spare parts

Specifications are subject to change without notice.
 Issue: February 2019